

CLASSIC SERIES INSTALLATION GUIDE

Supplied Hardware

Stainless Steel M2.5 bolt (1 per fin)
#6 Specialty screw (1 per hole in back of post)
NOTE: Ensure adequate backing in wall, 1-1/2" backing recommended. Wall anchors may be required if fastening to masonry.

Tools Required

Aluminium blade + chop saw
(if posts cut on site)
Level or Laser
Drill + drill bit
#1 Robinson bit
2mm Allen Key

Additional Suggested Tools

Makita 1/4" Hex Driver Drill (DF012D), torque setting 5
DeWalt 12" Extension (DW1589)
AM-2mm Apex 1/4" Socket Head

- Remove components from packaging. Be sure to recycle! Confirm fin supports supplied matches type, colour and quantity as per Liquid Systems order.
- Determine location on wall.
Note: Ensure adequate bottle space either side to existing and future objects. See Specification Guide for spacing requirements.
Note: If light shelves are integral to purchased display, refer to Light Shelf Installation guide for wiring locations.
- Mark edge or centreline of post on, or close to floor.
- By use of a level or laser, mark the edge or centerline of post on or close to the ceiling to ensure a plumb installation.
- If posts are cut on site: Measure overall floor to ceiling height at marked location and cut post to length using an aluminium blade and chop saw. **(Diagram #1)**
Note: Be sure to trim the correct end as key holes are specific to this vertical orientation.
Note: If multiple posts are being installed, ensure level and alignment of bottle display. First post (or multiple posts) may need to be trimmed top and bottom to gain a level installation over multiple posts.
- Lean post against a wall and align with top and bottom edge markings laid out from step #4 and #5.
- Mark holes with pencil per hole in back of post. **(Diagram #2)**
- Set aside post and pre-drill into wall surface and blocking behind with a 1/16" (1.5mm) drill bit, ensuring alignment with markings from previous step. **(Diagram #3)**
Note: If light shelves are part of the installation, refer to Light Shelf Installation guide for wiring instructions prior to securing post to wall.
- Secure post with #6 Specialty screws (supplied). **(Diagram #4)**
- Repeat steps #2 to #9 for multiple post installations, ensuring adequate space between posts. (Refer to Specification Guide for spacing requirements)
- Open packaging with fin supports and remove hardware from packaging.
Note: Supplied hardware = 1 x M2.5 Stainless Steel bolt per fin.

Diagram #1 :: Cut post to length

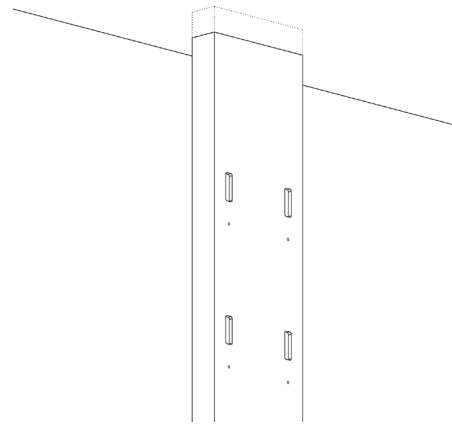

Diagram #2 :: Mark holes on wall

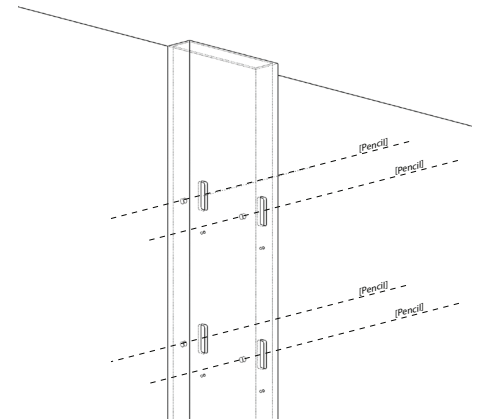
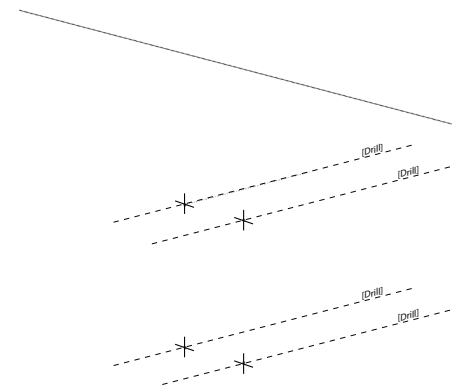

Diagram #3 :: Pre-drill holes in wall



CLASSIC SERIES INSTALLATION GUIDE

12. Install fins (or Light Shelves, see Light Shelf installation guide) individually so the pre-drilled hole in fin aligns with the threaded hole in post. **(Diagram #5)**
Note: Start installation from the lowest fin location and work up. This allows any gentle tapping from above if required on snug fitting fins.
13. Once key of fin is installed and fin is nested on post, secure fin by installing M2.5 bolt (supplied) and finger tighten with 2mm allen key.
Note: Use allen key only in orientation shown as to not create excessive torque. Finger-tight is all that is required to make a snug fit. Use extreme caution not to over-tighten and strip thread in post.
Note: Makita 1/4" Hex Driver Drill (model DF012D only) may be used on torque setting 5 to tighten M2.5 bolts. The use of other drill models and torque settings may over-tighten and strip tread in post.
14. Repeat steps #12 and #13 until all fins/ light shelves are installed. **(Diagram #6)**
15. Sit back and enjoy!

Diagram #4 :: Secure post to wall

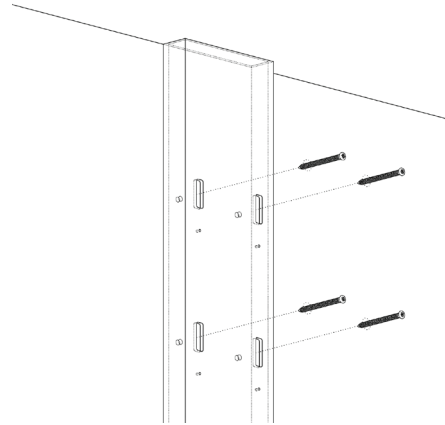

Diagram #5 :: Install fins and components

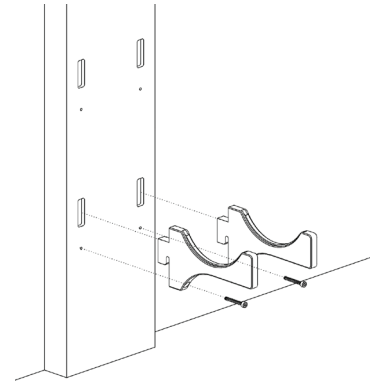

Diagram #6 :: Keep on going!

